

European Organisation for Technical Approvals
Europäische Organisation für Technische Zulassungen
Organisation Européenne pour l'Agrément Technique

ETAG 001

Edition June 1997
Amended July 2008

GUIDELINE FOR EUROPEAN TECHNICAL APPROVAL
OF
METAL ANCHORS
FOR USE IN CONCRETE

Part 3: Undercut Anchors

EOTA©
Avenue des Arts 40
Kunstlaan
1040 Brussels

TABLE OF CONTENTS

INTRODUCTORY NOTES	2
2 SCOPE	2
2.1.1 Types and operating principles	2
2.1.1.1 Displacement-controlled installations	3
2.1.1.2 Torque-controlled installations	6
2.1.3 Dimensions	6
4 REQUIREMENTS FOR WORKS	7
5 METHODS OF VERIFICATION	7
5.1 Methods related to 4.1 (mechanical resistance and stability)	7
5.1.2 Tests for suitability	7
5.1.2.0 Setting tests	7
5.1.2.1 Tests for installation safety acc. to Table 5.1 line 1	9
5.1.2.2 Tests according to Table 5.1, lines 2 to 6	10
5.1.2.3 Functioning under repeated loads	10
5.1.2.4 Torque tests	11
5.1.2.5 Sensitivity to brittle fracture	11
6 ASSESSING AND JUDGING THE FITNESS OF ANCHORS FOR AN INTENDED USE	14
6.1 Assessing and judging related to 4.1 (mechanical resistance and stability)	14
6.1.1.1 Criteria valid for all tests	14
6.1.2.2.7 Minimum spacing s_{min} and minimum edge distance c_{min}	14
6.7 Identification of anchors	14

INTRODUCTORY NOTES

The requirements, criteria and test information additional to ETAG 001 Part 1 for undercut anchors are given in this Part. The same numbering of paragraphs as in Part 1 is used. If a paragraph is not mentioned, then the text in Part 1 applies without modification.

References:

- [1] EN ISO 6507-1; 2005: Metallic Materials – Vickers hardness test - Part 1: Test method
 [2] EN ISO 6508-1; 2005: Metallic Materials – Rockwell hardness test - Part 1: Test method

2 SCOPE

2.1 Anchors

2.1.1 Types and operating principles

Undercut anchors are characterised by mechanical interlock provided by undercut in the concrete.

The undercutting can be achieved by:

- Hammering or turning (or combination of both) the anchor sleeve into a drilled undercut hole.
- Driving the anchor sleeve on to the tapered bolt in a cylindrical hole either by hammering or turning (or combination of both). The concrete is mostly cut away rather than compressed.
- Screwing the anchor into a pre-drilled cylindrical drill hole. The special thread of the anchor cuts an internal thread into the concrete member while setting.

The expansion into the undercut position shall be easily verifiable after anchor installation, e.g. by a mark on the anchor.

The following types of installations can be distinguished

2.1.1.1 Displacement-controlled installations

With anchors according to Fig. 2.1, 2.2, 2.4 and 2.5, the cylindrical holes should be drilled with a stop-drill to ensure their correct depth.

a) Undercut drilled before anchor installation

The different types of anchor installation are described in Figures 2.1 to 2.3:

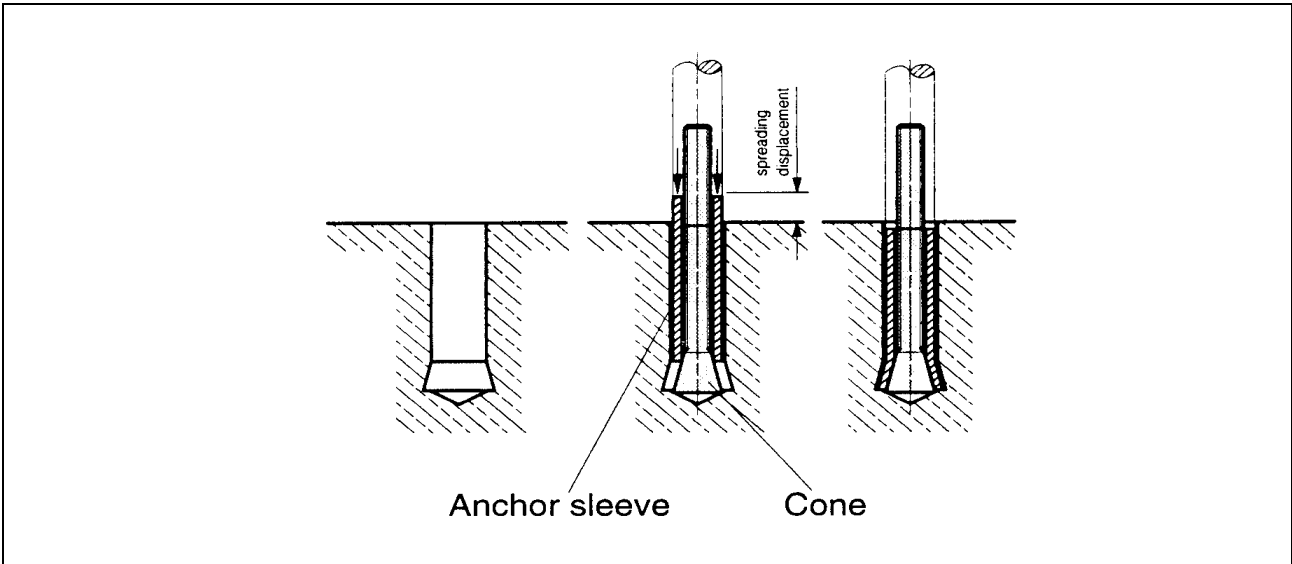

Figure 2.1 Anchor installation by hammering the anchor sleeve onto the cone

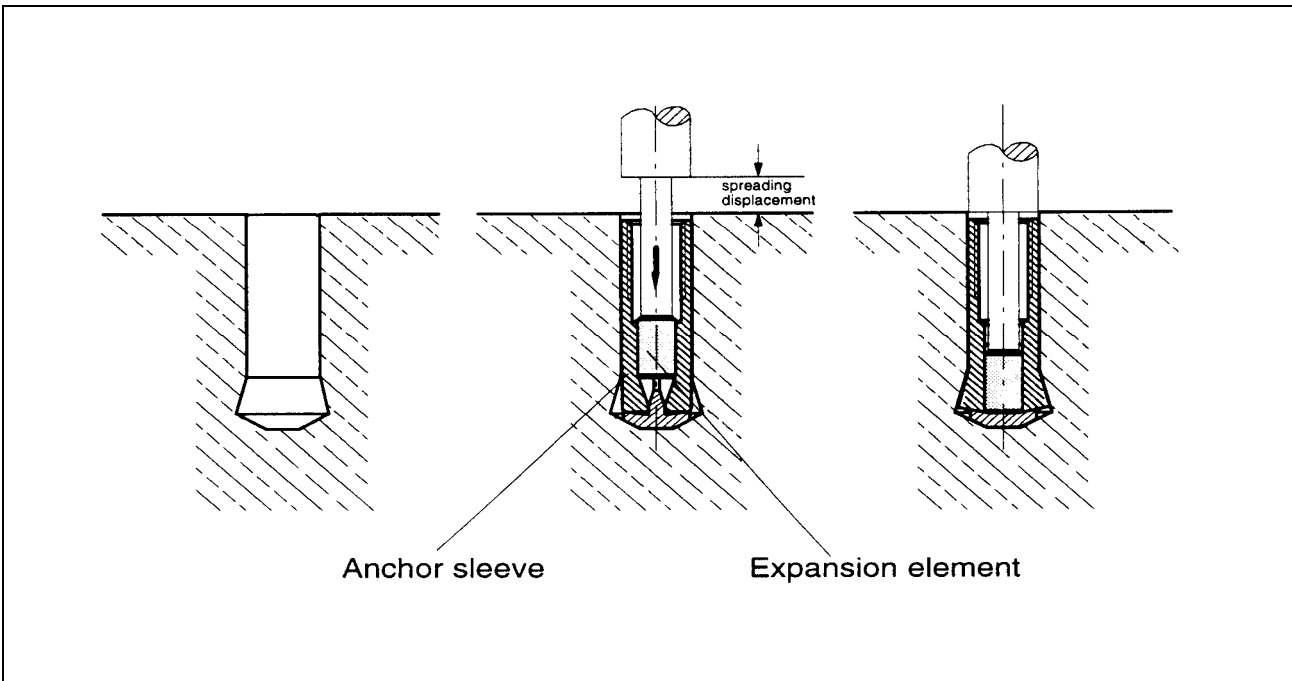

Figure 2.2 Anchor installation by hammering the expansion element (cone) into the anchor sleeve

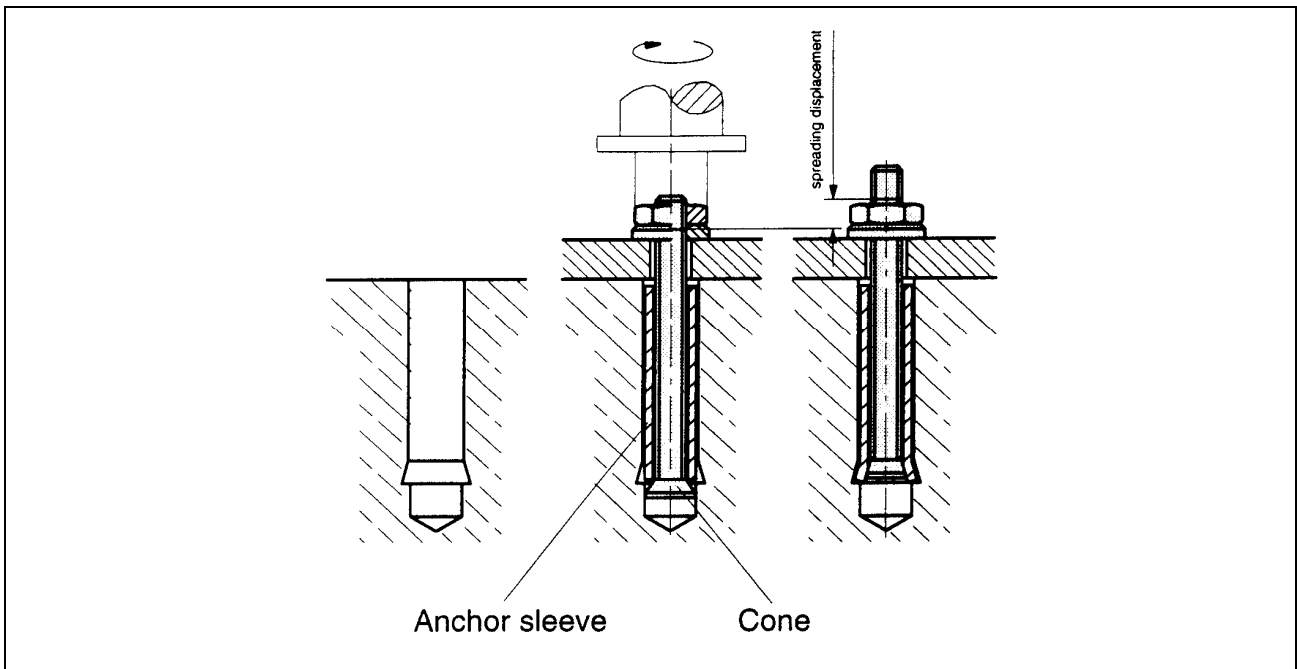

Figure 2.3 Anchor installation by pulling the cone with a defined expansion displacement into the anchor sleeve by turning the nut. This can be achieved by a special installation tool.

b) Undercut made during the setting of the anchor (self-cutting undercut anchors), including concrete screws

The different types of anchor installation are described in Figures 2.4 to 2.6.

A combination of Figure 2.4 and 2.5 is also possible.

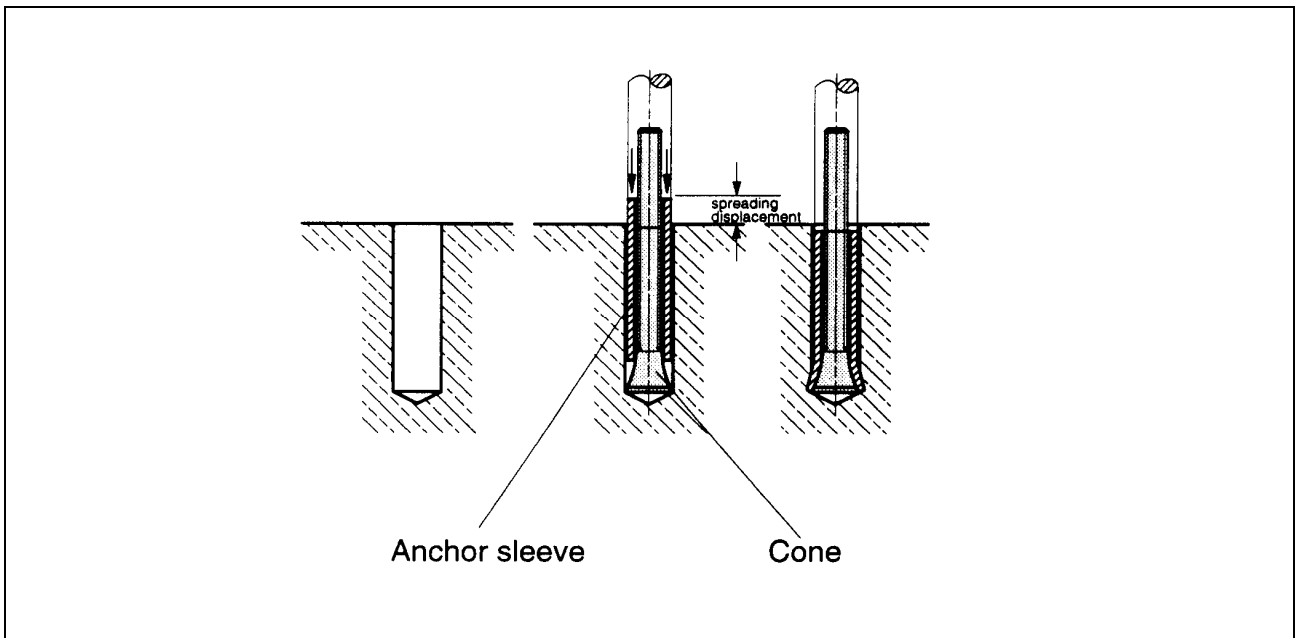

Figure 2.4 Anchor installation by hammering the sleeve over the cone; e.g. by using a drilling machine

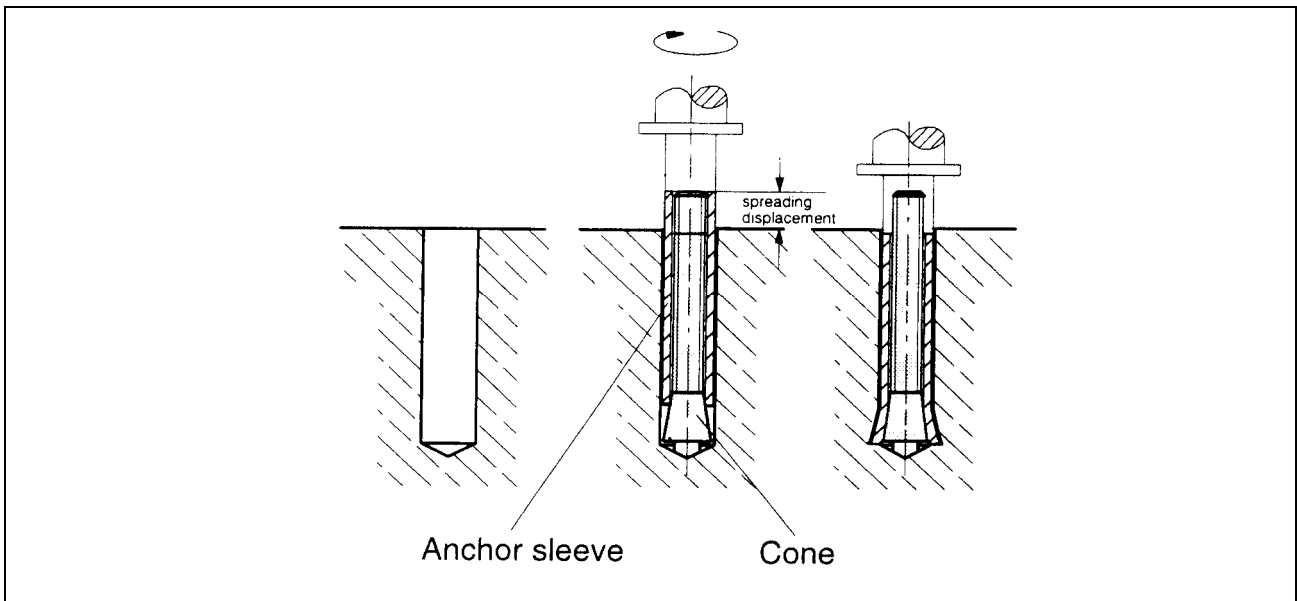

Figure 2.5 Anchor installation by rotating the anchor sleeve, e.g. by means of the drilling machine; thereby undercutting the concrete and forcing the sleeve over the cone. To facilitate the undercutting, the end of the anchor sleeve can be specially designed (e.g. with cutting pins)

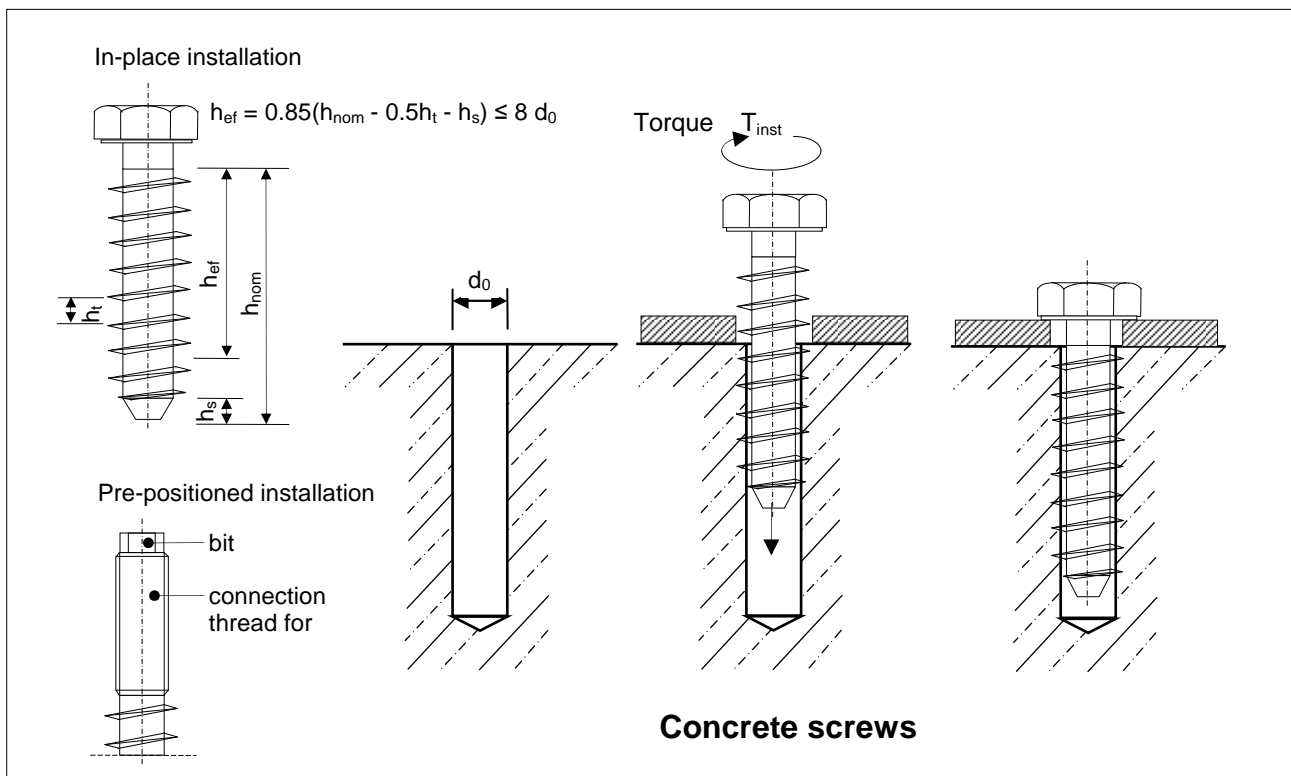

Figure 2.6 Installation by driving the concrete screw with a self cutting special thread with wrench or impact screw driver in predrilled cylindrical hole.

Concrete screws

The anchor is screwed into a pre-drilled cylindrical hole. The special thread of the anchor cuts an internal thread into the concrete member while setting. The installation may be done by a non-calibrated torque wrench, a calibrated torque spanner or an electrical or pneumatic impact screw driver. The anchorage is characterised by mechanical interlock in the concrete thread.

The anchor may be used only once.

The effective anchorage depth of concrete screws shall be determined acc. to Figure 2.6.

Concrete screws with a thread over the entire anchorage depth are covered only.

2.1.1.2 Torque-controlled installations

The different types of anchor installation are described in Figures 2.7 and 2.8.

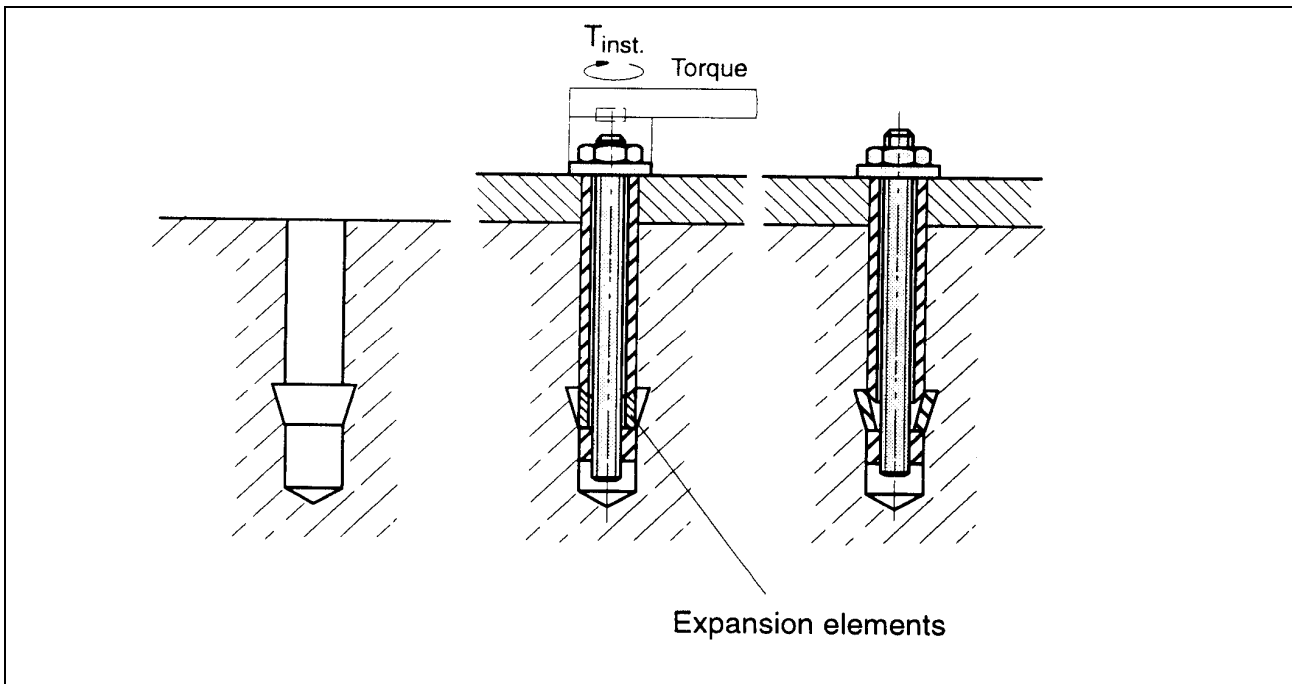

Figure 2.7 Anchor installation by forcing the expansion elements against the undercut by applying a defined torque moment

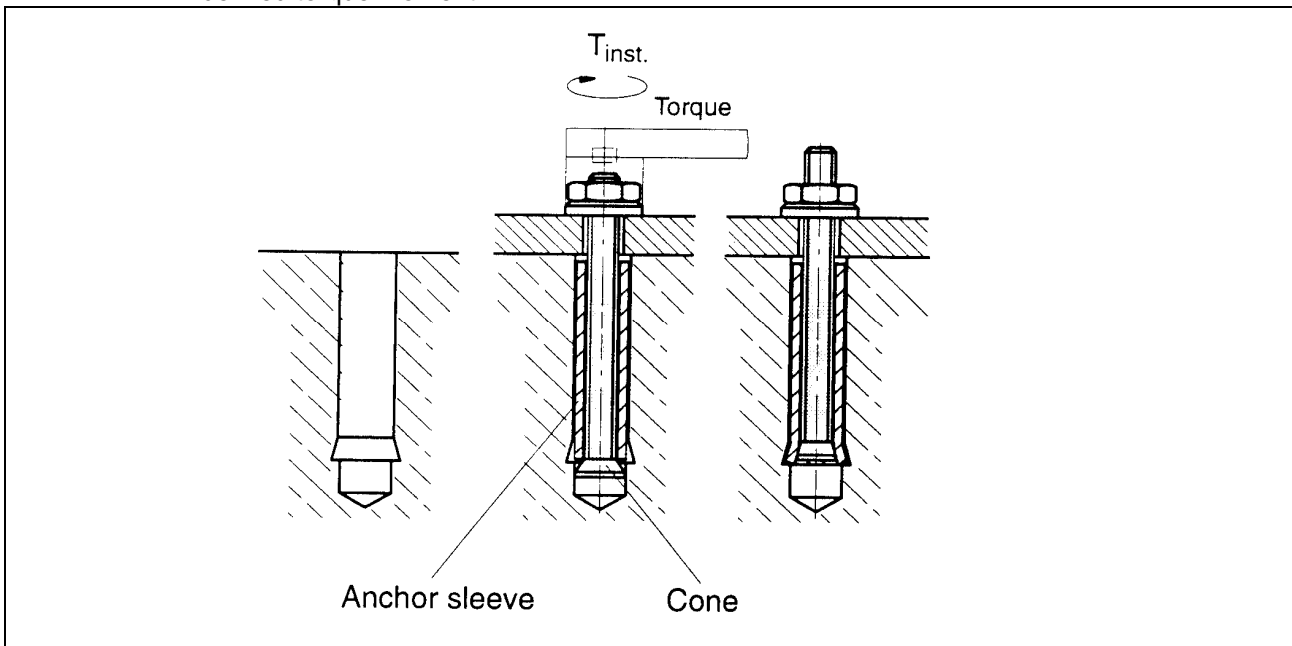

Figure 2.8 Anchor installation by pulling the cone into the anchor sleeve by applying a defined torque moment

2.1.3 Dimensions

In general Part 1, 2.1.3 applies with the following explanations for concrete screws acc. to Figure 2.6:

- Diameter: the shaft of the concrete screw applies
- The requirement for the minimum anchorage depth is fulfilled with the condition $(h_{nom} - h_s) \geq 40$ mm acc. to Figure 2.6

4 REQUIREMENTS FOR WORKS

4.1.2.6 Types of installation

When installing undercut anchors by displacement control (see Figure 2.1 to 2.5), the amount of energy input for full expansion should be relatively small (e.g. up to 4 hammer blows or 15 seconds installation time with a drilling tool).

To ensure the clamping of the fixture against the concrete surface, correctly installed undercut anchors shall be positioned such, that after anchor installation including tightening the anchor with the maximum allowable torque moment, the sleeve does not bear against the fixture (pre-positioned installation) or the washer (in-place installation) respectively.

5 METHODS OF VERIFICATION

5.1 Methods related to 4.1 (mechanical resistance and stability)

In addition to the measurements required in Part 1, the following measurements should be performed and the results recorded:

Displacement-controlled installation (see Figures 2.1 to 2.5)

- Length of the stop drill (if used)
- Dimensions of the drill bit for undercutting the concrete (if used)
- Position of the sleeve in relation to the concrete surface (pre-positioned installation) or the fixture (in-place installation) respectively, after anchor expansion and after the torque moment is applied, if applicable.
- Spreading displacement (relative displacement between sleeve and cone during expansion)

Torque-controlled installation (see Figures 2.7 and 2.8)

- Dimension of the drill bit for undercutting the concrete
- Position of sleeve in relation to the concrete surface (pre-positioned installation) or the fixture (in-place installation), respectively, after the torque moment is applied.
- Number of revolutions of the nut or bolt at the applied torque moment.

5.1.2 Tests for suitability

The types of tests, test conditions and the number of required tests as well as the criteria applied to the results are given in Table 5.1. This table is valid for anchors for use in cracked and non-cracked concrete. The tests shall be performed with single anchors without edge and spacing effects under tension loading.

5.1.2.0 Setting tests

Setting tests acc. to Table 5.1 line 0 (a), (b) and (c) are only required for concrete screws according to Figure 2.6. The tests shall be performed with the most adverse head form of the product. If the most adverse head form is not obvious all head forms shall be tested.

(a) Tests in low strength concrete

The following test conditions shall be kept:

- non- cracked concrete C20/25;
- Cutting diameter of drill bits $d_{cut} = d_{cut,max}$;
- 10 tests with each anchor size;
- The anchor shall be set with a calibrated torque wrench up to the designated depth. In tests with the pre-positioned anchor version with connecting thread the anchor shall be supported on the bottom of the drill hole ($h_1 \approx h_{nom}$). Afterwards the torque shall be increased up to failure; the ultimate torque moments of the test series (T_U) and the 5 % fractile of the ultimate torque shall be determined.

The following conditions shall be met:

- (1) It must be possible to properly set the anchor. The maximum torque moment to set the anchor with the designated setting depth and the torque moment to tighten the fixture must be $\leq T_{inst}$.
- (2) Tests with steel failure: $T_{U,5\%} \geq \gamma_{S,T} \times \gamma_3 \times T_{inst} \times f_{u,test} / f_{u,nom}$ (A)
- (3) Tests with concrete failure $T_{U,5\%} \geq \gamma_{C,T} \times \gamma_3 \times T_{inst} \times (f_{c,test} / f_{c,nom})^{0.5}$ (B)

where

$T_{U,5}$	5% fractile of the ultimate torque moments T_U
$\gamma_{S,T}$	= 1.5 partial safety factor for steel failure
$\gamma_{C,T}$	= 2.1 partial safety factor for concrete failure
γ_3	= 1.0 for coefficient of variation $v \leq 15\%$, = $1.0 + [v(\%) - 15] \times 0.03$ for coefficient of variation of ultimate torque moments 15 % < $v \leq 30\%$ according to ETAG 001-4, 6.1.1.1 (c), v coefficient of variation of ultimate torque moments.
T_{inst}	Installation torque recommended by the manufacturer (if no installation torque is specified by the manufacturer, T_{inst} should be determined in high strength concrete. T_{inst} is the maximum torque required to completely set the anchor in tests according to (b).
$f_{u,test}$	Tension strength of the anchor determined in identification tests
$f_{u,nom}$	Nominal tension strength of the anchor specified by the manufacturer
$f_{c,test}$	Concrete strength in the test series
$f_{c,nom}$	= 20 N/mm ² (measured on cylinders), nominal concrete strength required for the test.

If in all tests steel failure occurs, equation (B) may be omitted. If equation (B) is fulfilled, equation (A) may be omitted.

The anchor may only be set without control of the installation torque (e.g. with a wrench or ratchet without measured the applied torque) if in all tests steel failure occurs.

(b) Tests in high strength concrete

The following test conditions shall be kept:

- non-cracked concrete C50/60;
- Cutting diameter of drill bit $d_{cut} = d_{cut,min}$;
- 10 tests with each anchor size;
- The anchors are set with a calibrated torque wrench up to the designated setting depth. In tests with the pre-positioned anchor version with connecting thread the anchor shall be supported on the bottom of the drill hole ($h_1 \approx h_{nom}$). The maximum value of the required torque moment shall be measured. Afterwards, the torque shall be increased up to failure; the ultimate torque (T_U) and the 5 % fractile of the ultimate torque moments of the test series shall be determined.

The following test criteria shall be met:

- (1) It must be possible to properly set the anchor. The maximum torque moment to set the anchor with the designated setting depth and the torque moment to tighten the fixture must be $\leq T_{inst}$.
- (2) Tests with steel failure: $T_{U,5\%} \geq \gamma_{S,T} \times \gamma_3 \times T_{inst} \times f_{u,test} / f_{u,nom}$ (A)
- (3) Tests with concrete failure $T_{U,5\%} \geq \gamma_{C,T} \times \gamma_3 \times T_{inst} \times (f_{c,test} / f_{c,nom})^{0.5}$ (B)

where

$T_{U,5}$	5% fractile of the ultimate torque moments T_U
$\gamma_{S,T}$	= 1.5 partial safety factor for steel failure
$\gamma_{C,T}$	= 2.1 partial safety factor for concrete failure
γ_3	= 1.0 for coefficient of variation $v \leq 15\%$, = $1.0 + [v(\%) - 15] \times 0.03$ for coefficient of variation of ultimate torque moments 15 % < $v \leq 30\%$ according to ETAG 001-4, 6.1.1.1 (c). v coefficient of variation of ultimate torque moments in tests with concrete failure (failure of the concrete thread)
T_{inst}	Installation torque recommended by the manufacturer (if no installation torque is specified by the manufacturer, T_{inst} should be taken as the maximum torque required to completely set the anchor.
$f_{u,test}$	Tension strength of the anchor determined in identification tests
$f_{u,nom}$	Nominal tension strength of the anchor specified by the manufacturer
$f_{c,test}$	Concrete strength in the test series
$f_{c,nom}$	=50 N/mm ² (measured on cylinders), nominal concrete strength required for the test.

If in all tests steel failure occurs, equation (B) may be omitted.

(c) Tests with impact screw driver

The following test conditions shall be kept:

- Non-cracked concrete C20/25;
- Cutting diameter of drill bits $d_{\text{cut}} = d_{\text{cut,max}}$;
- 15 tests with each anchor size;
- Impact screw driver with maximum power output specified in the manufacturer's installation instructions for the anchor size. Because the power output given by the manufacturer of the screw driver may not be valid for setting the test institute should select the screw driver with maximum power output for this application from the screw drivers on the market fulfilling the specifications of the anchor manufacturer based on its experience or the results of the pre-tests.
- The anchor shall be set up to the designated depth; afterwards the impact screw driver shall be set on the head of the anchor with maximum power output. The screw driver shall be switched off automatically after 5 seconds.

The following conditions shall be met:

In all 15 tests no failure shall occur. If the test number is increased to $n = 30$ in one test failure may occur.

5.1.2.1 Tests for installation safety acc. to Table 5.1 line 1

The test conditions for undercut anchors to check the installation safety in respect of anchorage intensity should be based on the anchor type and type of installation. In these tests the anchors shall be installed such that a minimum bearing area is achieved. This condition is fulfilled if the following provisions are met.

a) Displacement-controlled installation

In general, the installation safety tests should be carried out in low strength concrete only, because in case of concrete cone failure for a constant bearing area the ratio concrete pressure in the bearing area to concrete compression strength decreases with increasing concrete strength.

Anchor installation according to Figure 2.1

- Diameter of drill bit for cylindrical hole d_0 : $d_{\text{cut,max}}$
- Length of drill bit for cylindrical hole: maximum length according to specified tolerances
- Diameter of drill bit for undercutting d_1 : $d_{\text{cut,max}}$
- Installation of anchor flush with the concrete surface or the fixture respectively.

Anchor installation according to Figure 2.2

- Diameter of drill bit for cylindrical hole d_0 : $d_{\text{cut,max}}$
- Diameter of drill bit for undercutting d_1 : $d_{\text{cut,max}}$
- Displacement of expansion element: shall be defined depending on anchor design either as a function of the required displacement, if the full anchor displacement can easily be recognized (e.g. by indentation of the anchor sleeve by the setting tool) or as a function of the required input energy for full anchor expansion or as a combination of both.

Anchor installation according to Figure 2.3

- Diameter of drill bit for cylindrical hole d_0 : $d_{\text{cut,max}}$
- Diameter of drill bit for undercutting d_1 : $d_{\text{cut,max}}$
- Expansion displacement depends on the installation tools. If the expansion can be done only with a special installation tool and the required expansion displacement can easily be recognized, then the actual expansion displacement should reflect the possible tolerances.

Installation according to Figures 2.4 and 2.5

- Diameter of drill bit for cylindrical hole d_0 : $d_{\text{cut,max}}$
- Length of drill bit for cylindrical hole: maximum length according to specified tolerances
- Installation of anchor flush with the concrete surface or the fixture respectively.
- If it is required by the manufacturer to apply a defined torque moment, then the anchors shall be torqued with $T = 1.0 T_{\text{inst}}$, after about 10 minutes the torque moment shall be reduced to $T = 0.5 T_{\text{inst}}$. If no defined torque moment shall be applied, then the anchors shall not be torqued before testing ($T = 0$).

Installation according to Figure 2.6

- Diameter of drill bit for cylindrical hole d_0 : $d_{cut,max}$
- The dimensions of anchors in the given tolerance range shall be about the minimum external diameter of the thread and minimum core diameter. If the dimensions of the anchor do not comply with these limits, drill bits with larger cutting diameter shall be used in order to provide minimum mechanical interlock.

b) Torque-controlled installation

For undercut anchors which are installed by torque control according to Figures 2.7 and 2.8 the test conditions in the installation safety tests are defined as follows:

- Diameter of drill bit for cylindrical hole d_0 : $d_{cut,max}$
- Diameter of drill bit for undercutting d_1 : $d_{cut,max}$ and $d_{cut,min}$ (anchors according to Figure 2.7 only)
- Torque moment $T = 0.5 T_{inst}$
- Concrete strength C20/25 and C50/60

5.1.2.2 Test according to Table 5.1, lines 2 to 6a

In the tests according to lines 2 to 6 the anchors should be installed according to the instructions of the manufacturer.

If for anchors installed according to Figures 2.1 to 2.5 it is required by the manufacturer to apply a defined torque moment, then the anchors shall be torqued with $T = 1.0 T_{inst}$, after about 10 minutes this torque moment shall be reduced to $T = 0.5 T_{inst}$. If for these anchors no defined torque moment shall be applied, then the anchors shall not be torqued before testing ($T = 0$).

Anchors according to Figures 2.7 and 2.8 shall be torqued with $T = 1.0 T_{inst}$; after about 10 minutes this torque moment shall be reduced to $T = 0.5 T_{inst}$.

5.1.2.3 Functioning under repeated loads

For concrete screws acc. to Figure 2.6 the suitability tests under repeated loads according to Table 5.1, line 6 b shall be modified as follows:

The anchor shall be set on beveled washers (inclination angle $\geq 4^\circ$) and shall be prestressed with the recommended installation torque T_{inst} . The corner of the hexagon nut must rest on the beveled washer. The position is shown in Figure 5.1. When the installation torque $T = T_{inst}$ is applied, the anchor head might just reached the beveled washer (see Figure 5.1 a) or might be fully pressed against the washer (see Figure 5.1 c). Any position of the anchor head between the extreme positions shown in Figure 5.1 is acceptable.

If the manufacturer applies for different head forms, the anchor with the most unfavourable head form shall be tested. The greatest moment in the shaft and the greatest notch effect shall be considered. If the most unfavourable head form is not obvious all head forms shall be tested.

After installation of the anchor as described above, the tests shall be carried out following ETAG 001, Annex A, section 5.6.

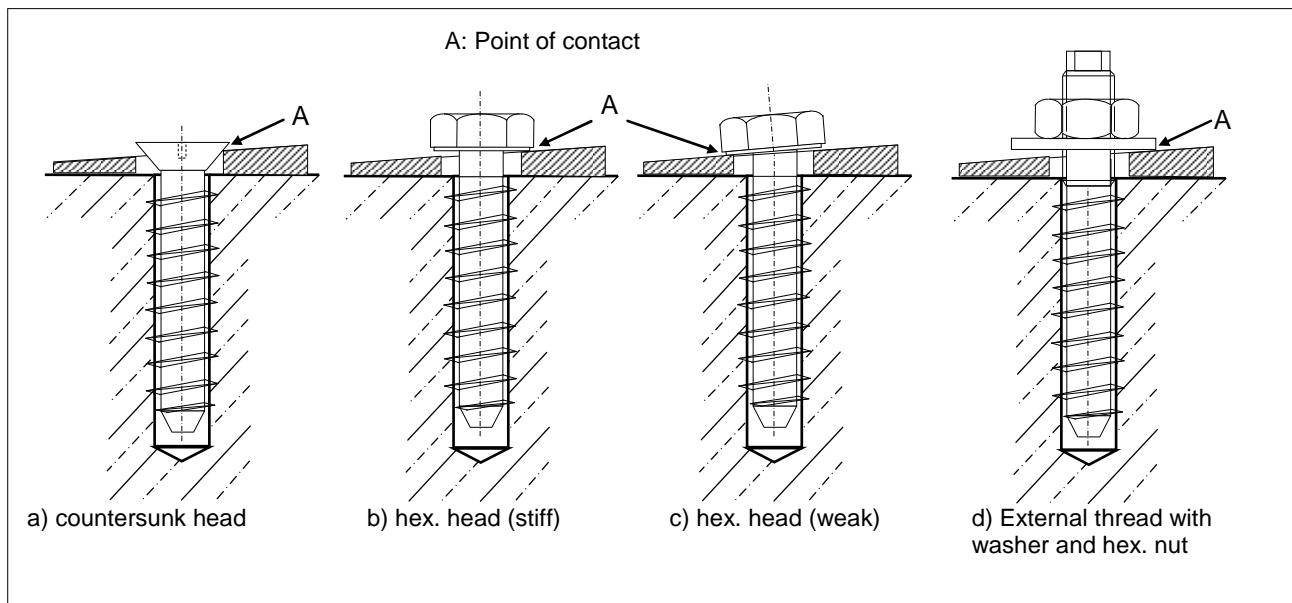

Figure 5.1 Position of the anchor head on beveled washers in tests with repeated loads

5.1.2.4 Torque tests

In the tests according to Table 5.1, line 7, the cylindrical hole and (if required) the undercut shall be drilled with a drill bit of medium tolerances ($d_{cut,m}$). The anchor shall be installed according to the instructions of the manufacturer.

5.1.2.5 Sensitivity to brittle fracture

Purpose and method of testing

This test for concrete screws acc. to Figure 2.6 may be omitted if

- concrete screws are made of stainless steel
- it is ensured by factory production control, that the strength of the steel in the area of load transfer is less than 1000 N/mm² and hardness <350 HV acc. to EN ISO 6507; < 36 HRC acc. to EN ISO 6508

Screws of high strength may be sensitive to brittle fracture due to hydrogen embrittlement caused by the production process or by corrosion during (even short -time) exposure to moisture. The test is designed to detect anchors with a high susceptibility to hydrogen induced brittle fracture and will be performed under conditions of constant mechanical load and hydrogen evolution on the surface of the screw. For this purpose an electrolyte similar to concrete pore solution (saturated calcium hydroxide solution) will be applied while the sample is kept under constant and defined electrochemical conditions (at constant potential of -955 mV vs. normal hydrogen electrode (NHE)) by potentiostatic control or by other appropriate means. The potential is measured controlled by means of a reference electrode. The test setup is shown schematically in Figure 5.2.

Preparation of samples

In case the screws are coated or galvanized, the coating must be removed partially (in shape of a longitudinal strip) to allow hydrogen evolution on the steel surface.

Test conditions:

Test member: high strength concrete C50/60

Test solution: saturated solution (in distilled water) of calcium hydroxide with small excess of Ca(OH)₂ powder to obtain a milky appearance. The pH will then attain about 12,6 (± 0.1) at 25°C and remain almost constant during the test. Calcium hydroxide powder should be kept in an air-tight containment and should not be stored longer than one year.

The test solution should be filled into a bottomless container covering an area of at least 96cm² with a height of at least 25mm, which shall be affixed to the concrete (see Figure 5.2). During the test the head of the concrete screw shall be submerged in the fluid.

Sustained load: $N_{HE} = \min \{0.5 N_{st,mean}; 0.7 N_{u,mean}\}$
with

$N_{st,mean}$ = average ultimate steel capacity determined from tensile tests on anchor specimens or, alternatively
= $A_s \cdot f_{uk}$, where f_{uk} is the nominal tensile strength of the anchor and A_s is the cross section of the shaft of the anchor

$N_{u,mean}$ = average ultimate tensile load of the tests according to ETAG 001 Part 1 Table 5.4 line 2, normalised to C50/60

The anchor shall be set on beveled washers (inclination angle $\geq 4^\circ$) as shown in Figure 5.2.

Electrochemical conditions:

Potential: -955 mV vs. NHE.

Reference electrode: any kind of „second order“ electrode (calomel, silver/silver chloride etc.) may be used. The potential value shall be corrected according to the reference value given by the manufacturer, e.g. for a saturated calomel electrode with $E_{cal} = +245$ mV vs. NHE the correct potential will be $E = -955 - 245 = -1200$ mV (±10 mV).

Counter electrode: stainless steel or activated titanium (used as anode for cathodic protection)

Temperature range: 20 to 25°C

Duration of test: 100 hours. Following the test, after unloading the screw, an unconfined tension test to failure shall be performed.

Test Criteria:

During the constant load portion of the test (100 hours), no anchor shall fail. If concrete failure occurs the test shall be repeated.

The failure load of residual load bearing capacity shall be compared to reference tension tests according to reference tests in C50/60. The reduction factor shall fulfil req. $\alpha \geq 0.9$.

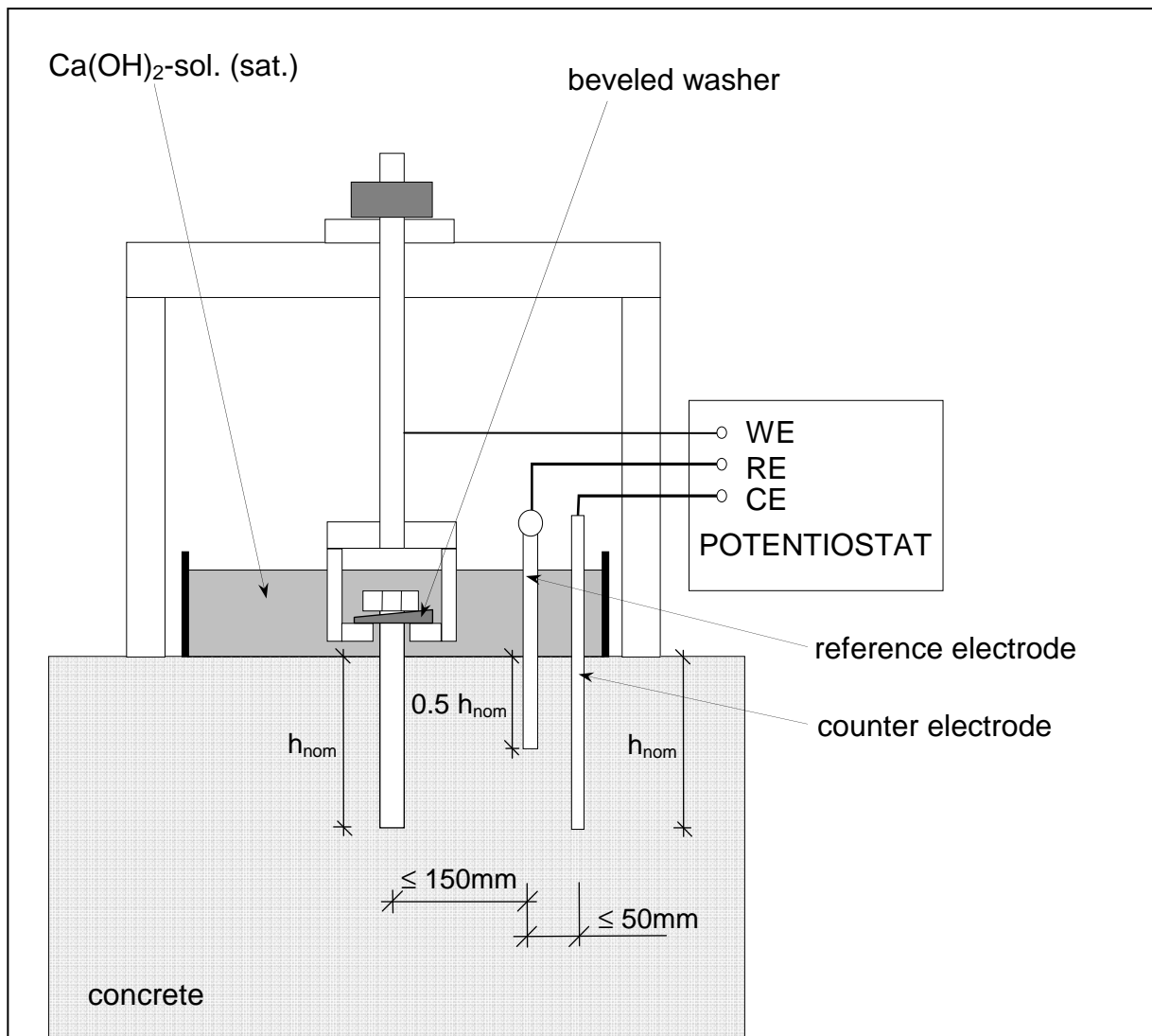
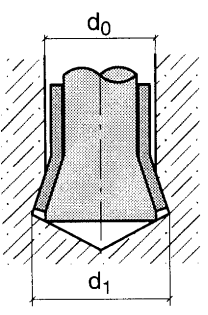

Figure 5.2 Test setup (schematic)

Table 5.1: Suitability tests for undercut anchors to be used in cracked and non-cracked concrete

	Purpose of test	Concrete	Crack width Δw (mm)	Drill bit or diamant core bit d_{cut}		Minimum number of tests for anchor size					Criteria		Remark	Test procedure described in
						s	i	m	i	l	load/displacement behaviour	ultimate load req. α (3)		
0	(a) Setting tests in low strength concrete	C20/25	0	$d_{cut,max}$	-	10	10	10	10	10	-	-	(13), (15)	5.1.2.0
	(b) Setting tests in high strength concrete	C50/60	0	$d_{cut,min}$	-	10	10	10	10	10	-	-	(13), (15)	5.1.2.0
	(c) Setting tests with impact screw driver	C20/25	0	$d_{cut,max}$	-	15	15	15	15	15	-	-	(13)	5.1.2.0
1	Installation safety (a) anchorage intensity	C20/25 (11)	0.3	(7),		5	5	5	5	5	Part 1, 6.1.1.1	≥ 0.8 (4)	(5), (6)	Annex A 5.2.1
2	(b) contact with reinforcement	C20/25	0.3	$d_{cut,m}$, (14)	$d_{cut,m}$, (14)	5	5	-	-			≥ 0.7 (4)	(2), (6)	Annex A 5.8
3	Functioning in low strength concrete	C20/25	0.5	$d_{cut,max}$	$d_{cut,max}$	5	5	5	5			≥ 0.8	(5), (6)	Annex A 5.2.1
4	Functioning in high strength concrete	C50/60	0.5	$d_{cut,min}$	$d_{cut,min}$	5	5	5	5	5		≥ 0.8	(5), (6)	Annex A 5.2.1
5	Functioning in crack-movements	C20/25	0.1 - 0.3	$d_{cut,m}$	$d_{cut,m}$	5	5	5	5	5	Part 1, 6.1.1.1 and 6.1.1.2 (a)	≥ 0.9	(5), (6)	Annex A 5.5
6	(a) Functioning under repeated loads	C20/25	0	$d_{cut,m}$	$d_{cut,m}$	-	-	3	-	-	Part 1, 6.1.1.1 and 6.1.1.2 (b)	≥ 1.0	(8),	Annex A 5.6
	(b) tests with concrete screws on beveled washers					5	5	5	5	5		≥ 1.0	(12), (13)	5.1.2.3
7	Maximum torque moment	C50/60	0	$d_{cut,m}$	$d_{cut,m}$	5	5	5	5	5	-	(9)	(10)	Annex A 5.10
8	Sensitivity to brittle fracture	C50/60	0	$d_{cut,m}$	$d_{cut,m}$	5	5	5	5	5		≥ 0.9	(13)	5.1.2.5

Notes to Table 5.1

- (1) Anchor size
s = smallest
l = intermediate
m = medium
l = largest
- (2) Necessary only for anchors with $h_{ef} < 80$ mm to be used in concrete members with a reinforcement of spacing < 150 mm.
- (3) α see Part 1, Equation (6.2)
- (4) Valid for $\gamma_2 = 1.2$. For other values of γ_2 see Part 1, 6.1.2.2.2.
- (5) If less than three anchor sizes are tested together and/or the different anchor sizes are not similar in respect of geometry, then the number of tests shall be increased to 10 for all anchor sizes.
- (6) If the coefficient of variation of the failure loads is $v \geq 10\%$ or the coefficient of variation of the anchor

displacements at a load $F = 0.5 F_{Ru,m}$ ($F_{Ru,m}$ = average failure load in a test series) is $v \geq 30$ %, then the number of tests in this test series shall be increased to $n = 10$.

- (7) Test conditions see 5.1.2.1
- (8) If anchors are not similar in respect of geometry, then other sizes shall also be tested.
- (9) See Part 1, 6.1.1.2 (d)
- (10) The number of sizes to be tested may be reduced or these tests may be omitted if it can be shown by experience that the requirement according to Part 1, 6.1.1.2 (d) will be fulfilled.
- (11) For anchors according to Figures 2.7 and 2.8 the tests shall be performed in C20/25 and C50/60.
- (12) For tests with concrete screw acc. to Figure 2.6 the tests shall be performed on beveled washers, see section 5.1.2.3.
- (13) Tests required for concrete screws acc. to Figure 2.6 only.
- (14) For tests with concrete screw acc. to Figure 2.6 drill bits with a diameter $d_o = d_{cut,max}$ should be used. The dimensions of anchors in the given tolerance range shall be about the minimum external diameter of the thread and minimum core diameter. If the dimensions of the anchor do not comply with these limits, drill bits with larger cutting diameter shall be used in order to provide minimum mechanical interlock.
- (15) The tests may be omitted for concrete screws which cannot be set physically with a torque wrench

5.1.3 Tests for admissible service conditions

The test conditions are given in Part 1, 5.1.3 and Annex B. They are summarized in Part 1, Table 5.4, which applies to anchors to be used in cracked and non-cracked concrete according to Option 1.

In addition to the tests in Part 1, Table 5.4, line 20 to derive the minimum edge distance and minimum spacing, tension tests according to Annex A shall be performed with double anchor group parallel to the edge ($s = s_{min}$, $c = c_{min}$, $h = h_{min}$) if the average prestressing force at the maximum torque moment given by the manufacturer is smaller than the characteristic failure load for concrete failure according to Annex C.

6 ASSESSING AND JUDGING THE FITNESS OF ANCHORS FOR AN INTENDED USE

6.1 Assessing and judging related to 4.1 (mechanical resistance and stability)

6.1.1.1 Criteria valid for all tests

a) Load/displacement behaviour

Uncontrolled slip of an anchor occurs if the expansion sleeve or expansion elements are significantly moving in the drilled hole. This can be caused by failure of the highly loaded concrete in the region of the undercut. This slip can be recognized by a reduction in load and/or a horizontal or nearly horizontal part in the load/displacement curve with a corresponding displacement of > 0.5 mm.

If uncontrolled slip is proven, refer to Part 1, 6.1.1.1a).

6.1.2.2.7 Minimum spacing s_{min} and minimum edge distance c_{min}

If tension tests shall be performed (see 5.1.3) then the characteristic failure load shall be equal to or larger than the value calculated according to Annex C for concrete cone failure. The largest value for c_{min} derived from the two types of tests governs.

6.7 Identification of anchors

If the surfaces of the cone or sleeve are treated in a special way, then in addition to the tests mentioned in Part 1, the roughness of the cone surface and the inner surface of the spreading sleeve shall be measured. Furthermore, if the cone and/or the sleeve are coated, this coating shall be identified and its thickness shall be measured. The results shall be compared with the specifications.